

POSIZIONE ANGOLARE DEL PERNO
RISPETTO ALLA TAMPOGRAFIA

ANGULAR POSITIONING PIN ACCORDING
TO PRINTED KNOB

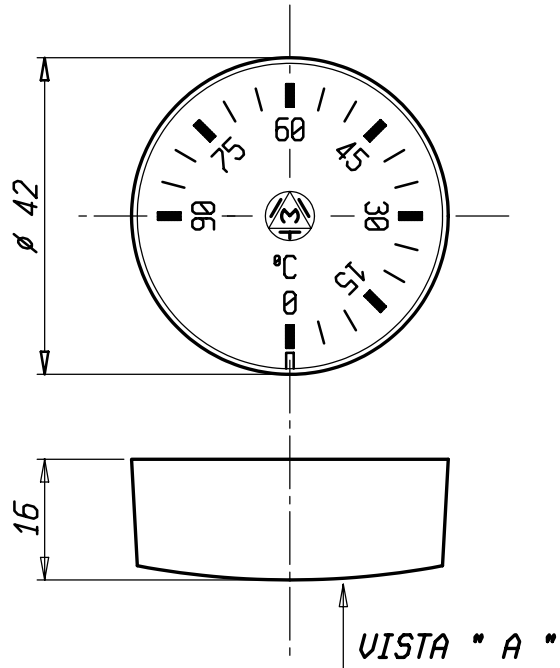

VISTA " A "

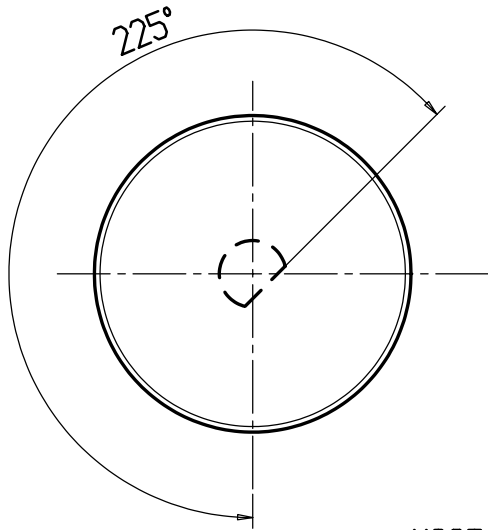
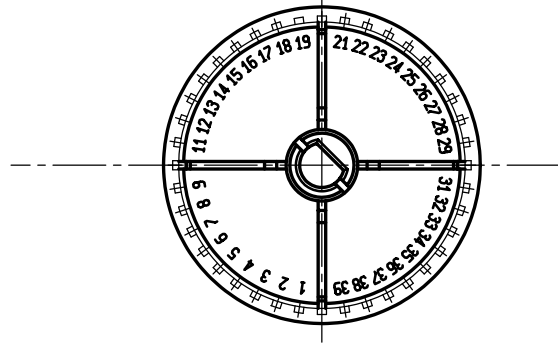

FONDO NERO
BLACK DIAL

SCRITTE BIANCHE
WHITE WRITING

SATINATURA SUPERFICIALE
SATIN FINISH

K5024 G STANDEX INTERNATIONAL

Note :

- 1- La tampografia deve risultare completa, uniforme e senza sbavature.
- 2- Usare cliche' CL. 1.
- 3- Utilizzare inchiostro colore BIANCO RAL 9016
- 4 -Utilizzare manopola grezza cod. 003496.
- 5 -Per altre quote ed indicazioni vedere disegno cod. 003496.
- 6 -Tipo di carattere: Univers bold condensed 2.8 mm

Pos.	Codice	Denominazione	N. Pezzi	Note																																																
		Materiale																																																		
		Trattamento																																																		
		Peso grezzo	Quote senza indicazione di tolleranza: precisione gruppo	Lunghezza lato minore α'																																																
		Peso finito	<table border="1"> <tr> <td>GRUPPO</td> <td>da 0 a < 6</td> <td>da 6 a < 30</td> <td>da 30 a < 120</td> <td>da 120 a < 315</td> <td>da 315 a < 1000</td> <td>da 1000 a < 2000</td> <td>OLTRE 2000</td> <td>da 0 a < 10</td> <td>da 10 a < 50</td> <td>da 50 a < 100</td> <td>OLTRE 100</td> </tr> <tr> <td>A</td> <td>± 0.05</td> <td>± 0.1</td> <td>± 0.15</td> <td>± 0.2</td> <td>± 0.3</td> <td>± 0.5</td> <td>-</td> <td>$\pm 1'$</td> <td>$\pm 30'$</td> <td>$\pm 20'$</td> <td>$\pm 10'$</td> </tr> <tr> <td>B</td> <td>± 0.1</td> <td>± 0.2</td> <td>± 0.3</td> <td>± 0.5</td> <td>± 0.8</td> <td>± 1.2</td> <td>± 2</td> <td></td> <td></td> <td></td> <td></td> </tr> <tr> <td>C</td> <td>± 0.2</td> <td>± 0.5</td> <td>± 0.8</td> <td>± 1.2</td> <td>± 2</td> <td>± 3</td> <td>± 4</td> <td></td> <td></td> <td></td> <td></td> </tr> </table>	GRUPPO	da 0 a < 6	da 6 a < 30	da 30 a < 120	da 120 a < 315	da 315 a < 1000	da 1000 a < 2000	OLTRE 2000	da 0 a < 10	da 10 a < 50	da 50 a < 100	OLTRE 100	A	± 0.05	± 0.1	± 0.15	± 0.2	± 0.3	± 0.5	-	$\pm 1'$	$\pm 30'$	$\pm 20'$	$\pm 10'$	B	± 0.1	± 0.2	± 0.3	± 0.5	± 0.8	± 1.2	± 2					C	± 0.2	± 0.5	± 0.8	± 1.2	± 2	± 3	± 4					
GRUPPO	da 0 a < 6	da 6 a < 30	da 30 a < 120	da 120 a < 315	da 315 a < 1000	da 1000 a < 2000	OLTRE 2000	da 0 a < 10	da 10 a < 50	da 50 a < 100	OLTRE 100																																									
A	± 0.05	± 0.1	± 0.15	± 0.2	± 0.3	± 0.5	-	$\pm 1'$	$\pm 30'$	$\pm 20'$	$\pm 10'$																																									
B	± 0.1	± 0.2	± 0.3	± 0.5	± 0.8	± 1.2	± 2																																													
C	± 0.2	± 0.5	± 0.8	± 1.2	± 2	± 3	± 4																																													
		Progetto N°																																																		
		Diseg.	VENEZIA S. 16/04/98	Verif. MARANDELLA 16/04/98																																																
		Scala	1:1																																																	
		Sost. il	556337-2																																																	
		dal																																																		
		Dis.	IMOTT s.p.a. 556337/3																																																	
		Denominaz.	MANOPOLA TAMPOGRAFATA / RUPPER-PAD PRINTED KNOB																																																	
		A4	Il presente disegno non puo essere riprodotto, copiato o comunicato a terzi senza la nostra autorizzazione, come a termine di legge sui diritti d' autore																																																	