

POSIZIONE ANGOLARE DEL PERNO
RISPETTO ALLA TAMPOGRAFIA

ANGULAR POSITIONING PIN ACCORDING
TO PRINTED KNOB

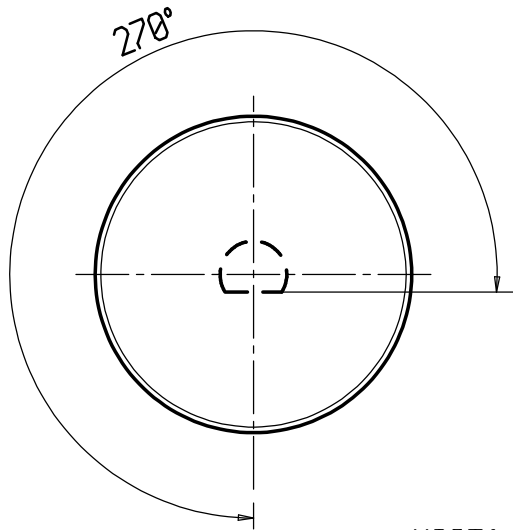

VISTA " A "

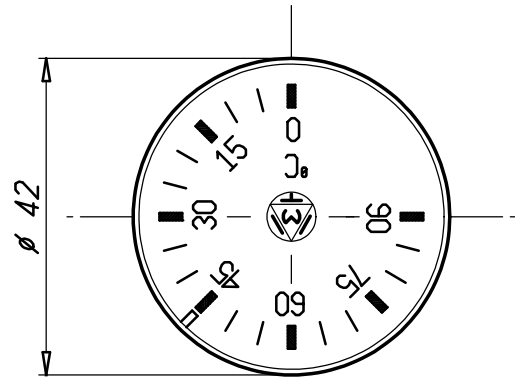

VISTA " A "



FONDO NERO
BLACK DIAL

SCRITTE BIANCHE
WHITE WRITING

SATINATURA SUPERFICIALE
SATIN FINISH

K5024 G STANDEX INTERNATIONAL

Note :

- 1- La tampografia deve risultare completa, uniforme e senza sbavature.
- 2- Usare cliché CL. 1.
- 3- Utilizzare inchiostro colore BIANCO "PLT9/160" (Collana Europea)
- 4 -Utilizzare manopola grezza cod. 003496.
- 5 -Per altre quote ed indicazioni vedere disegno cod. 003496.
- 6 -Tipo di carattere: Univers bold condensed 2.8 mm

Pos.	Codice	Denominazione	N. Pezzi	Note																																													
		Materiale																																															
		Trattamento																																															
		Peso grezzo	Quote senza indicazione di tolleranza: precisione gruppo	Lunghezza lato minore α'																																													
		Peso finito	<table border="1"> <tr> <td>GRUPPO</td> <td>da 0 a < 6</td> <td>da 6 a < 30</td> <td>da 30 a < 120</td> <td>da 120 a < 315</td> <td>da 315 a < 1000</td> <td>da 1000 a ≤ 2000</td> <td>OLTRE 2000</td> <td>da 0 a < 10</td> <td>da 10 a < 50</td> <td>da 50 a ≤ 100</td> <td>OLTRE 100</td> </tr> <tr> <td>A</td> <td>±0.05</td> <td>±0.1</td> <td>±0.15</td> <td>±0.2</td> <td>±0.3</td> <td>±0.5</td> <td>-</td> <td>±1'</td> <td>±30'</td> <td>±20'</td> <td>±10'</td> </tr> <tr> <td>B</td> <td>±0.1</td> <td>±0.2</td> <td>±0.3</td> <td>±0.5</td> <td>±0.8</td> <td>±1.2</td> <td>±2</td> <td></td> <td></td> <td></td> <td></td> </tr> <tr> <td>C</td> <td>±0.2</td> <td>±0.5</td> <td>±0.8</td> <td>±1.2</td> <td>±2</td> <td>±3</td> <td>±4</td> <td></td> <td></td> <td></td> <td></td> </tr> </table>	GRUPPO	da 0 a < 6	da 6 a < 30	da 30 a < 120	da 120 a < 315	da 315 a < 1000	da 1000 a ≤ 2000	OLTRE 2000	da 0 a < 10	da 10 a < 50	da 50 a ≤ 100	OLTRE 100	A	±0.05	±0.1	±0.15	±0.2	±0.3	±0.5	-	±1'	±30'	±20'	±10'	B	±0.1	±0.2	±0.3	±0.5	±0.8	±1.2	±2					C	±0.2	±0.5	±0.8	±1.2	±2	±3	±4		
GRUPPO	da 0 a < 6	da 6 a < 30	da 30 a < 120	da 120 a < 315	da 315 a < 1000	da 1000 a ≤ 2000	OLTRE 2000	da 0 a < 10	da 10 a < 50	da 50 a ≤ 100	OLTRE 100																																						
A	±0.05	±0.1	±0.15	±0.2	±0.3	±0.5	-	±1'	±30'	±20'	±10'																																						
B	±0.1	±0.2	±0.3	±0.5	±0.8	±1.2	±2																																										
C	±0.2	±0.5	±0.8	±1.2	±2	±3	±4																																										
Progetto N°																																																	
Diseg.	COLOMBO D.	24-01-2000	Verif. CAPITANIO	24-012000																																													
Scala	1:1	Sost. il																																															
		dal																																															
				IMOTT s.p.a.																																													
				Dis. 556654																																													
		Denominaz.	MANOPOLA TAMPOGRAFATA / RUPPER-PAD PRINTED KNOB																																														
	A4	Il presente disegno non può essere riprodotto, copiato o comunicato a terzi senza la nostra autorizzazione, come a termine di legge sui diritti d'autore																																															